

EQ120

1/3" B/W Digital CCD Camera

User's Manual
and
Operation Instructions

Notice

This manual is presented to the users of EQ120 by EverFocus Electronics Corp. With years of engineering researches, EverFocus has spared no effort to provide the high quality products to the worldwide users. For the policy of continual product improvement, EverFocus reserves the right to make changes to the product specifications and documentation without notice. All the components of the products, including accessories, components, and outlook, are based on the agreements of each deals to satisfy all kinds of users. Meanwhile, please be advised that every step of operation must follow the instruction of this manual to keep EQ120 working under the best condition. Please notice that EverFocus will not be charged any claims or renewing cases resulted from inappropriate operation.

Table of Contents

<i>Safety Warning</i>	<i>1</i>
<i>Introduction</i>	<i>2</i>
<i>Specification</i>	<i>3</i>
<i>Major Parts and Their Functions</i>	<i>4</i>
<i>Installation Instructions</i>	<i>8</i>



CAUTION

RISK OF ELECTRIC SHOCK
DO NOT OPEN



CAUTION:
TO REDUCE THE RISK OF ELECTRIC SHOCK, DO NOT REMOVE
COVER (OR BACK), NO USER SERVICEABLE PARTS INSIDE.
REFER SERVICING TO QUALIFIED SERVICE PERSONNEL



The lightning flash with arrowhead symbol, within an equilateral triangle, is intended to alert the user to the presence of uninsulated "dangerous voltage" within the product's enclosure that may be of sufficient magnitude to constitute a risk of electric shock to persons.



The exclamation point within an equilateral triangle is intended to alert the user to the presence of important operating and maintenance (servicing) instructions in the literature accompanying the appliance.

We declare under our sole responsibility that the product to which this declaration related is in conformity with the standards or other normative documents following the provisions of Directives EEC/73/23 and EEC/89/336.

Safety Warning

1. **Handle the camera with care.**

Be careful when handling the camera, do not drop it or subject it to strong shock or vibration to prevent any damages to it. Do not disassemble it or place it on an unstable base.

2. **Do not install the camera near electric or magnetic fields.**

Installed the camera away from TV, radio transmitter, magnet, electric motor, transformer, audio speakers because the magnetic fields generate from above devices will distort the video image.

3. **Do not install the camera in the high temperature environment.**

Installed the camera away from stoves, or other heat generating devices as the high temperature could cause deformation, discoloration or other damages of the camera. Install the camera at where the temperature range will stay between 0°C to 50°C (32°F to 122°F).

4. **Never face the camera toward the sun.**

Never aim the camera at the sun or other extremely bright objects whether it is in use or not.

5. **Cleaning**

Do not touch the surface of CCD sensor by hand directly. Use a soft cloth to remove the dirt from the camera body. Use lens tissue or a cotton tipped applicator and ethanol to clean the CCD sensor and the camera lens. When the camera is not in use, put the cover cap on the lens mount.

Introduction

The new EQ120 series is a solid-state B/W video camera specially designed for high quality surveillance applications. It incorporates break through DSP technology that provides most reliable and accurate B/W picture in security industry. The camera is convenient to use with C-mount or CS-mount lenses and has an easy back-focus adjustment help to achieve installation efficiency.

Main Features :

- 1/3" B/W CCD pick up device for more than 420 TV lines of horizontal resolution
- Sophisticated DSP (Digital Signal Processing) circuitry design that delivers excellent picture quality and performance.
- Wide range automatic electronic shutter: 1/50(1/60)~1/100,000 sec
- Auto line lock with external phase adjustment
- Used with either C-mount or CS-mount lenses and easy back-focus Adjustment.
- System available in EIA or CCIR.

Specification

Pickup Device	1/3" SONY B/W CCD
Picture Elements	510 x 492 (EIA) 500 x 580 (CCIR)
Horizontal Resolution	420 TV lines
Sensitivity	0.01 lux/F=1.2
S/N Ratio	Over 48 dB (AGC off)
Electronic Shutter	1/50(1/60) ~ 1/100,000 sec
Auto Iris	Video / Direct Drive switch
Flickerless	On/Off
Back Light Comp.	On/Off
Electronic Shutter	On/Off
Auto Gain Control	On/Off
Line Lock	On/Off
Audio	Optional
Gamma Correction	0.45
Video Output	BNC 1.0Vp-p,75 ohm
Power Source	2 types: 12VDC/24VAC, 90~260VAC
Power Consumption	5W max
Dimensions	50mm(H) x 57mm (W) x 140.2mm(D); 1.97" (H) x 2.24"(W) x 5.52" (D)
Operating Temperature	0°C~50°C ; 32°F~122°F (20%~80% Humidity)
Certifications	FCC/CE

Major Parts Names and Their Functions

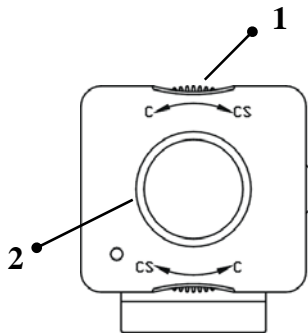

Front

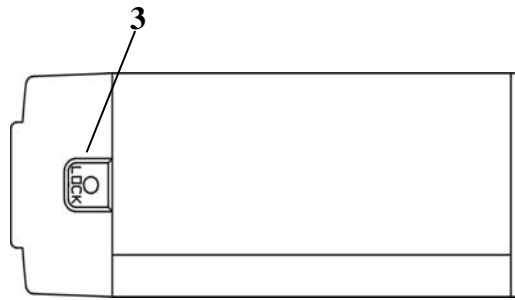

Side

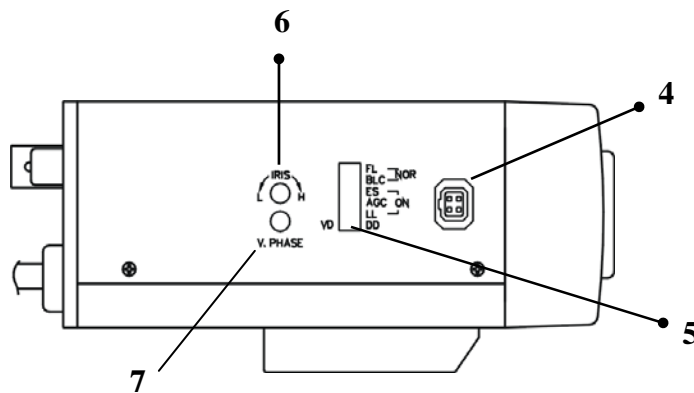

Side

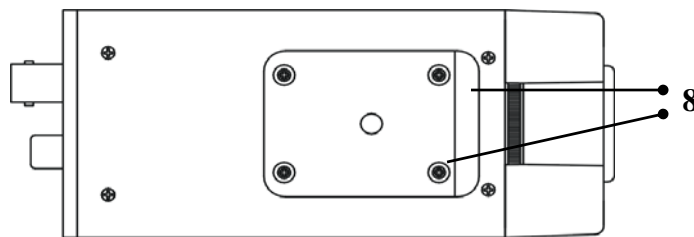

Top

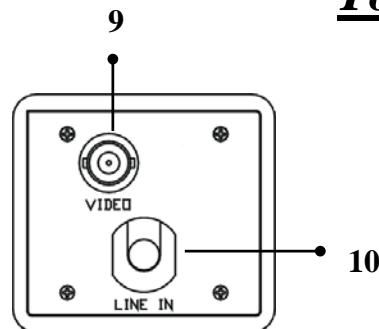

Rear (EQ120)

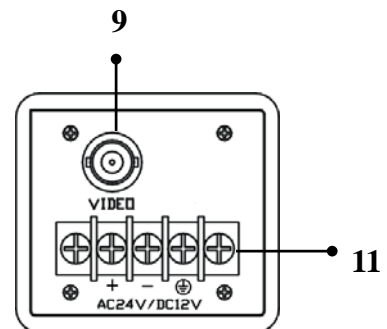

Rear (EQ120A)

1. Focal Length Adjustment Ring

Use this ring to adjust the appropriate focal length according to the type of lens. Rotate the ring clockwise for the CS-mount lens, rotate it counterclockwise for the C-mount lens. The factory setting is C-mount.

2. Lens Mount

To mount an appropriate C-mount or CS-mount lens.

3. Locking Screw

Use the locking screw to fix the focal length.

4. Lens Connector (4 pin socket)

To connect to the lens plug of the auto IRIS lens.

5. Control Switches

There are 6 control switches located on the sideboard, which are for the setting of the special features. The switches in orders are for Flickerless, Back Light Compensation, Electronic Shutter, Automatic Gain Control, Line-Lock and Auto Iris Lens type.

FL(Flickerless) On/Normal

When picture flicker fiercely, turn FL on, then the camera will stabilize the speed of electronic shutter at 1/100(EIA) or 1/120(CCIR) automatically, and reduce the flicker immediately. The default setting is Normal.

BLC (Back Light Compensation) On/Normal

When BLC is turned on, the AGC, ES and IRIS operating point is determined by averaging over the center area instead of entire field-of-view, so that a dimly-lit foreground object at center area can be clearly distinguished from brightly-lit backgrounds.

BLC should not be used unless it is needed to compensate for back-lit. The default setting is Normal.

ES (Electronic Shutter) Off/On

ES ON: The camera continuously adjusts the shutter speed from 1/60 (EIA), 1/50(CCIR) second to 1/100,000 second according to the luminance conditions of the scene.

ES OFF: The shutter speed is fixed at 1/60 (EIA), 1/50 (CCIR) second.

Set ES OFF, when auto iris lens is used or flicker is observed under a very bright fluorescent lamp. Otherwise, turn ES on for optimum performance. The default setting is ON.

AGC (Automatic Gain Control) Off/On

AGC ON: The sensitivity increases automatically when light is low.

AGC OFF: A-low-noise picture is obtained under a low light condition.

The default setting is ON.

LL (Line-Lock) Off/On

To select the sync mode between Internal Sync.(LL off) and Line-Lock (LL on).

Set the line-lock off, the camera will synchronize to the internal time base. Set the line-lock on, the camera's vertical synchronization can be driven by the AC signal in the power lines.

Note: Line-Lock sync mode operation is possible only when used with an AC power source; it's not possible with a DC power source.

VD/DD (Auto Iris lens Type)

For video drive auto iris lens, please set switch to VD. For direct drive iris lens, set switch to DD. The default setting is DD. Wire the cable of lens to lens connector according to the following table.

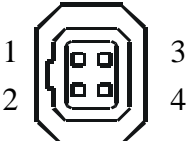
	<u>Pin1</u>	<u>Pin2</u>	<u>Pin3</u>	<u>Pin4</u>	Lens Connector
Video Drive	+12V	GND	VD-IRIS	GND	
Direct Drive	Cnt-	Cnt+	Drv+	Drv-	

6. IRIS Level Control

Brightness Level can be adjusted from the IRIS level VR while using the direct drive lens.

- Turn counterclockwise to L to get darker picture.
- Turn clockwise to H to get brighter picture.

7. V-Phase Adjustment

The vertical phase may require adjustment to synchronize the vertical phase of the camera with other camera in the system when it is to be used in the line-lock sync mode. Make the adjustment when the vertical phase of the camera does not match with other cameras.

8. Mounting Base and Fixing Screws

To use when the mounting bracket is required while mounting the camera. The mounting base can be attached to either the top or the bottom of the camera, fix the mounting base onto the camera by using the 4 supplied fixing screws.

9. Video Output Connector

BNC VBS 1.0 Vp-p, 75ohm

10. Power Cable (EQ120)

11. 12VDC/24VAC Screw Terminals (EQ120A)

Installation Instructions

1. Remove the cover cap from the top of the lens mount.
2. To attach a C-mount/CS-mount lens, turn the focal length adjustment ring to the appropriate position.

Note: If a C-mount lens is used, please make sure the focal length adjustment ring is set at C position before fixing the lens.
3. Screw the lens firmly onto the lens mount. Insert the lens plug in the lens connector if the auto iris lens is used.
4. Tighten the locking screw.
5. Connect the video output of the camera to a color monitor or other video device through a 75 ohm type coaxial cable with BNC female connector.
6. Plug the power cord to the outlet.
7. Once the image appears on the monitor, adjust the focus and diaphragm of the lens to obtain the best picture.
8. If the subject is not in focus when adjusting focus of lens, do focal length adjustment as following:
 - i. Loosen the locking screw of the focal length adjustment ring.
 - ii. Take picture of subject at a distance more than 20m away from the camera.
 - iii. Rotate the focal length adjustment ring to bring the subject in focus.
 - iv. Tighten the locking screw while the adjustment is completed.

EverFocus Electronics Corp.

Head Office:

12F, No.79 Sec. 1 Shin-Tai Wu Road,
Hsi-Chih, Taipei, Taiwan
TEL: +886-2-26982334
FAX: +886-2-26982380
www.everfocus.com.tw

USA L.A. Office:

1801 Highland Ave. Unit A
Duarte, CA 91010, U.S.A.
TEL: +1-626-844-8888
FAX: +1-626-844-8838
www.everfocus.com

USA N.Y. Office:

415 Oser Avenue Unit S
Hauppauge, NY 11788
TEL: 631-436-5070
FAX: 631-436-5027
www.everfocus.com

Europe Office:

Albert-Einstein-Strasse 1
D-46446 Emmerich, Germany
TEL: 49-2822-9394-0
www.everfocus.de

China Office:

Room 609, Technology Trade Building,
Shangdi Information Industry Base, Haidian
District, Beijing, China 10085
TEL: +86-10-62973336/37/38/39
FAX: +86-10-62971423
www.everfocus.com.cn

Japan Office:

1809 WBG MARIBU East 18F,
2-6 Nakase.Mihama-ku.
Chiba city 261-7118, Japan
TEL: +81-43-212-8188

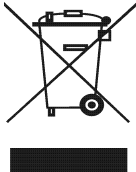
	<p>Your EverFocus product is designed and manufactured with high quality materials and components which can be recycled and reused. This symbol means that electrical and electronic equipment, at their end-of-life, should be disposed of separately from your household waste. Please, dispose of this equipment at your local community waste collection/recycling centre. In the European Union there are separate collection systems for used electrical and electronic product. Please, help us to conserve the environment we live in!</p>	<p>Ihr EverFocus Produkt wurde entwickelt und hergestellt mit qualitativ hochwertigen Materialien und Komponenten, die recycelt und wieder verwendet werden können. Dieses Symbol bedeutet, dass elektrische und elektronische Geräte am Ende ihrer Nutzungsdauer vom Hausmüll getrennt entsorgt werden sollen. Bitte entsorgen Sie dieses Gerät bei Ihrer örtlichen kommunalen Sammelstelle oder im Recycling Centre. Helfen Sie uns bitte, die Umwelt zu erhalten, in der wir leben.</p>
---	--	--



P/N: MQ12G0020A VerB