

# HC-92

## Charger for two handheld / belt-pack transmitters

- **Handheld** transmitters: SQ-9000 IrDA(R), SQ-6100 IrDA(R), SQ-2100 IrDA(R)
- **Belt-pack** transmitters: SM-9000 IrDA, SM-7100 IrDA, SM-6100 IrDA

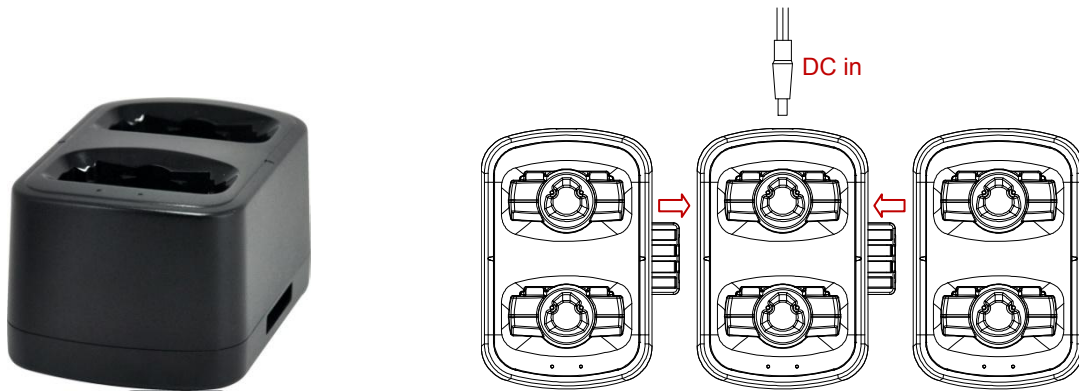

Sharing power with another two HC-92 chargers

## Specifications

MODEL	HC-92
Input Voltage	12VDC 2A
Over-charging prevention timer	10 hours
Quiescent current	17mA±5mA
Protection & control	1. Output short protection. 2. PWM for current control. 3. Time sharing for system control. 4. -ΔV、0ΔV、maximumV for battery detect technology.
Operating temperature range	0 -55°C on cell surface
Suitable batteries	Uses with Ni-MH batteries only
Displays	Red LED: Charging Green LED: Battery full Blue LED: Power indicator
Charged unit Q'ty	2
Size (mm)	95(W)*145(D)*75(H)
Weight (g)	257
Case	ABS Plastic