

IP-SDMF

PoE+ Indoor IP Endpoint with Speaker, LCD, Microphone, and LED Flasher



Features

Network Features

- Dynamic or Static IP Address
- IEEE 802.3 10/100Base-T Ethernet
- IEEE 802.1q Tagging
- IEEE 802.3af and 802.3at Compliant

Audio Codec Support

- G.711 u-law / a-law (16 kbit/s)
- G.722 Wideband Audio (64 kbit/s)

Auto Provisioning

- DHCP Option 66, 150, for TFTP Server
- DHCP Option 72 for HTTP Server

Auto Registration

- SLP for InformaCast
- DHCP Option 72 for Syn-Apps' Revolution

Static Configuration

- HTTP GUI for Static Configuration

Audio Features

- Integrated Amplifier
- Aux Audio Line-In Balanced (2.8Vpp 10K)
- Aux Audio Line-Out Balanced (2.8Vpp 10K)

Additional Features

- 2 General Purpose Inputs
- Cisco SRST
- 1 Relay Output (2A @ 30VDC)
- Phone / Night Loud Ringer
- External Power Supply Option
- LCD for Clock / Date and Scrolling Text
- Front Panel LED Flashers Allow for ADA Compliance
- Integrated Microphone Allows for Half-Duplex or Full-Duplex Paging Based on Software Platform Used

General Description

AtlasIED IP-SDMF is an indoor wall mount IP endpoint with speaker, integrated talkback microphone, LCD and LED flasher. It complements the Unified Communications (VoIP Communications) investment including on-premises and hosted infrastructure platforms so that information can be pushed to spaces beyond the world of desktop telephony communication and breaking any traditional audio-path barriers.

Applications

AtlasIED IP-SDMF registers as a communication endpoint directly within InformaCast, GCK, and Syn-Apps' Revolution advanced notification applications, supporting audio broadcast to enhance physical security while improving day-to-day communications through advanced alerting, bell schedules, pre-recorded & scheduled announcements, while leveraging the WAN or LAN network architecture.

When used within a Cisco environment, the IP-SDMF speakers can join Cisco's Unified Survivable Remote Site Telephony (SRST) as a supported device. Cisco's SRST provides remote location call-processing redundancy when access to the centralized Cisco Unified Communications Manager is interrupted because of a WAN outage. The ability of LAN communication between any combination of phones and speakers is particularly critical during an emergency (which may be the actual cause of the WAN outage).

Where 3rd party notification applications are not required, the IP-SDMF speakers can register as SIP devices directly to a SIP server or VoIP Communications Manager for critical alerts, intercom and public address applications.

Under Title II of the ADA, all state and local governments are required to take steps and ensure effective communication to people with disabilities. The AtlasIED IP-SDMF IP speakers with talkback microphone, LCD display and LED flasher provide effective communication for all individuals.

System	
Type	PoE+ Indoor IP Speaker System with LCD Display, Microphone and LED Flasher
Indicators	Network Status (On Back)
Frequency Response (+/- 5dB)	86Hz - 15.5kHz
Vertical Coverage	105° (2kHz Octave Band, -6dB Points)
Horizontal Coverage	105° (2kHz Octave Band, -6dB Points)
Directivity Factor (Q)	17 @ 2kHz
Max SPL at 1m (Passive)	110dB SPL Continuous
General Purpose Interface	Two Trigger Inputs / One Relay Output (2A @ 30 VDC)
Transducers	
LF Transducer Qty and Size	(1) 8" (203mm)
HF Transducer Qty and Size	(1) 3" (76mm)
HF Crossover Frequency	2,800Hz, First Order
Voice Coil Size	1" (25mm)
Cone Material	Curvilinear, Treated Industrial Paper
Sensitivity	98dB SPL Average
Amplification	
Type	Single-Channel Class D Topology with Primary and Secondary Outputs
AC Power Input	PoE or PoE+ and External 24VDC
Power Rating (RMS)	12 Watts Max (802.3AF) / 25 Watts Max (802.3AT)
THD	<0.2%
Cooling	Passive / Convection
Driver Protection	Built-In Limiter
Microphone	
Sensitivity	Minus 35 (±4dB) / (0db = 1V/pa, 1kHz)
Impedance	Less than 2.2k Ω
Directivity	Omnidirectional
Frequency Range	20Hz – 20kHz
Standard Operation Voltage	2V
Max. Operation Voltage	10V
Current Consumption Max.	0.5 mA
Sensitivity Reduction Within	Minus 3dB @ 1.5V
S/N Ratio	More than 62dB
Audio Inputs and Outputs	
Input: Analog Audio Type(s)	One Balanced Line Level
Input: Analog Connectivity	Secured Screw Terminal Block
Input: Network Audio Type(s)	G.711 U-Law / A-Law and G.722 Capable
Input: Network Connectivity	RJ-45 Female
Output: Analog Audio Type(s)	One Balanced Line Level
Output: Analog Connectivity	Secured Screw Terminal Block
Output: Digital Audio Type(s)	G.711 U-Law / A-Law and G.722 Capable (Multicast)
Output: Digital Connectivity	N/A
Output: Speaker Level	8Ω, 12W (802.3AF), 25W (802.3AT)
Output: Speaker Connectivity	Primary and Slave Secured Screw Terminal Block

Display	
Display Type	High Resolution Back-Lit Color LCD Display
Display Color Range	Backlit Display - Red, Blue, Green - (With GCK) Standard - Blue Text White
Surface Lumens	1900 cd/m ² Minimum, All White Pixels
Character Max Height	480 Pixels
Viewable Dimensions (H x W)	8.66" (221mm) x 2.23" (57mm)
Control	Time via NTP -Text Controlled via Software
Flasher	
Flasher Type	LED
Flash Color Range	RGB
Flasher Illuminance (lux)	83 Red, 545 Green, 90 Blue, 570 White
Flash Rate(s)	Multi Speed Capable
Viewable Dimensions (HxW)	0.5" (13mm) x 3.5" (89mm)
Control	Controlled via Software
Software	
GCK Compatible Version	3.0+
InformaCast Advanced Compatible Version	8.0+
InformaCast Fusion Compatible Version	3.0+
SA-Announce Compatible Versions	9.0.18+
Network	
Ethernet	IEEE 802.3 10/100Base-T
PoE	IEEE 802.3 AF/AT Compliant
VLAN	IEEE 802.1q Tagging
Protocols	
IP Addressing	DHCP / Static
Auto-Provisioning	HTTP / TFTP
Auto-Registration	HTTP / Service Location Protocol / IEDNet
Time	NTP or Host Server
Telephony	SIP
Enclosure	
Color	White
Grille Material	Powder Coated Steel
Baffle Material	Plastic
Mounting / Rigging Provisions	4 x Screws
Safety Agency Ratings	ETL Listed to Comply with 62368-1, CSA C22.2 #62368-1, IEC 62368-1 CB Scheme and FCC
Ingress Protection	N/A
Logo	One Color Print
Product Dimensions (HxWxD)	14.37" x 12.87" x 3.42" (365mm x 327mm x 87mm)
Shipping Dimensions (HxWxD)	15.5" x 13.9" x 5.5" (394mm x 353mm x 140mm)
Net Weight - lbs	4.25lb (1.92kg)
Shipping Weight - lbs	6.62lb (3.0kg)
Warranty Coverage	
Warranty Period	1 Year

NOTES:

1. Sensitivity: Half space pink noise measurement at 6 ft (1.8 m) at 20% power; extrapolated to 1 meter and an input of 2.83 volts RMS.
2. Watts: All wattage figures are calculated using the rated nominal impedance.
3. Frequency response and sensitivity are half-space measurements.

Polars Are Normalized To Zero On Axis (-6dB)

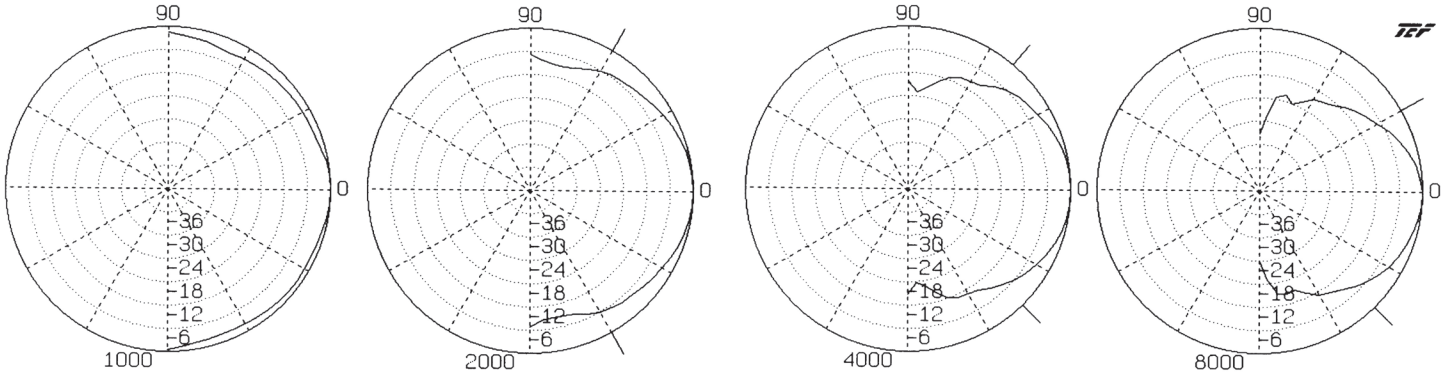

Frequency Response

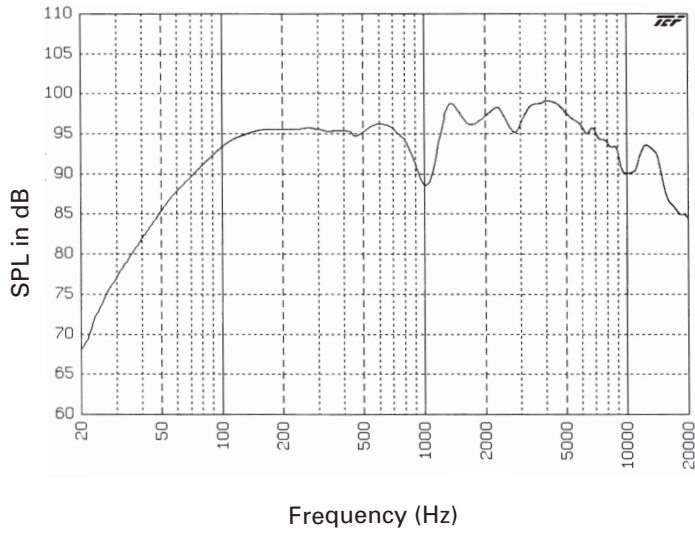

Impedance

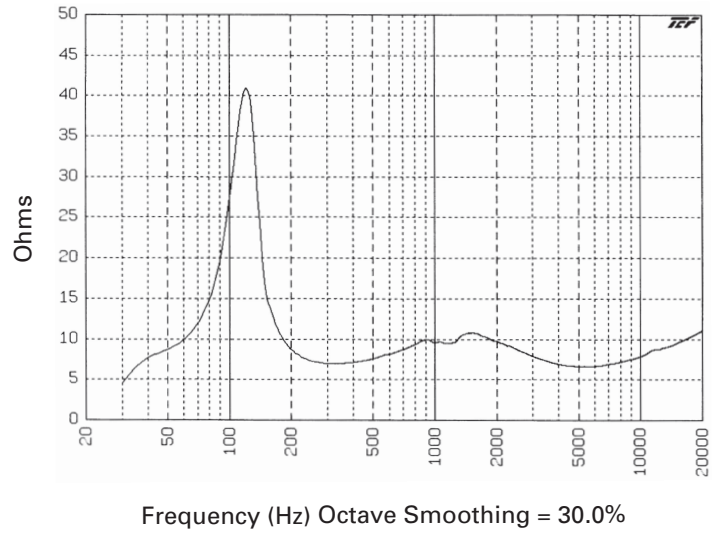

Dimensional Drawings

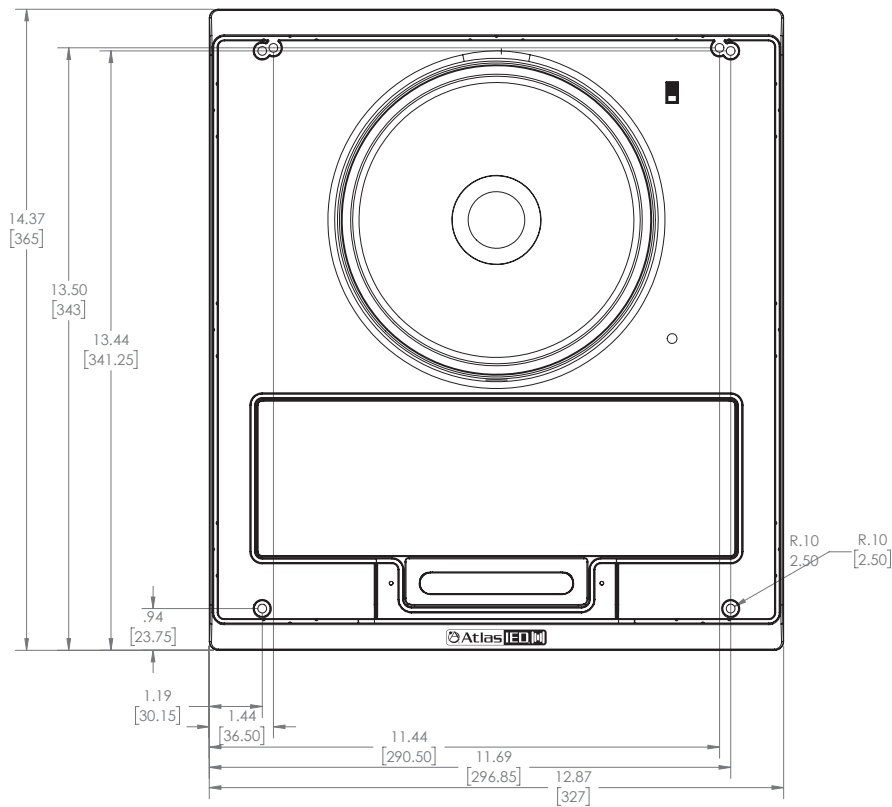
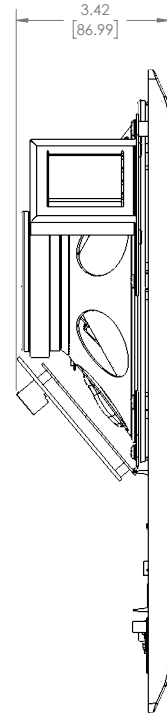
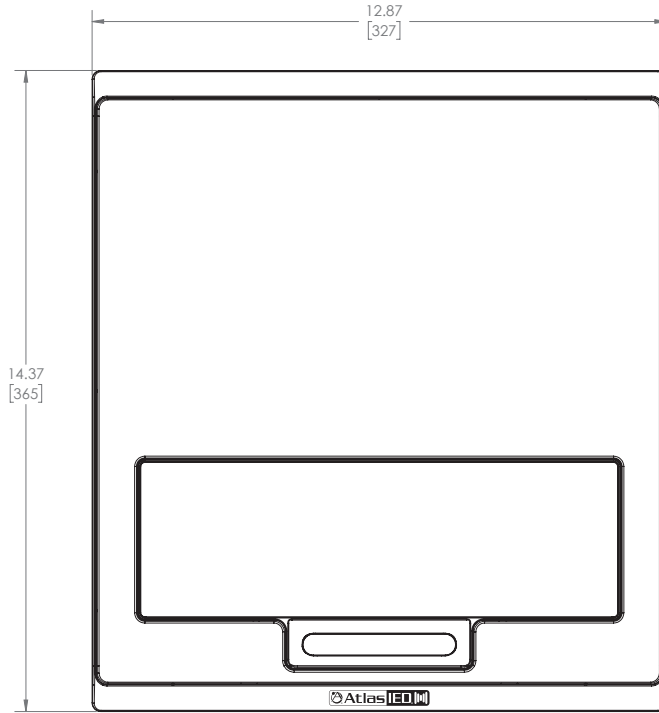

Accessories
IP-SEA-SD

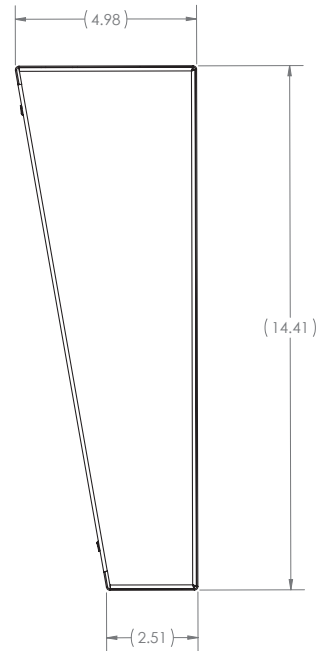
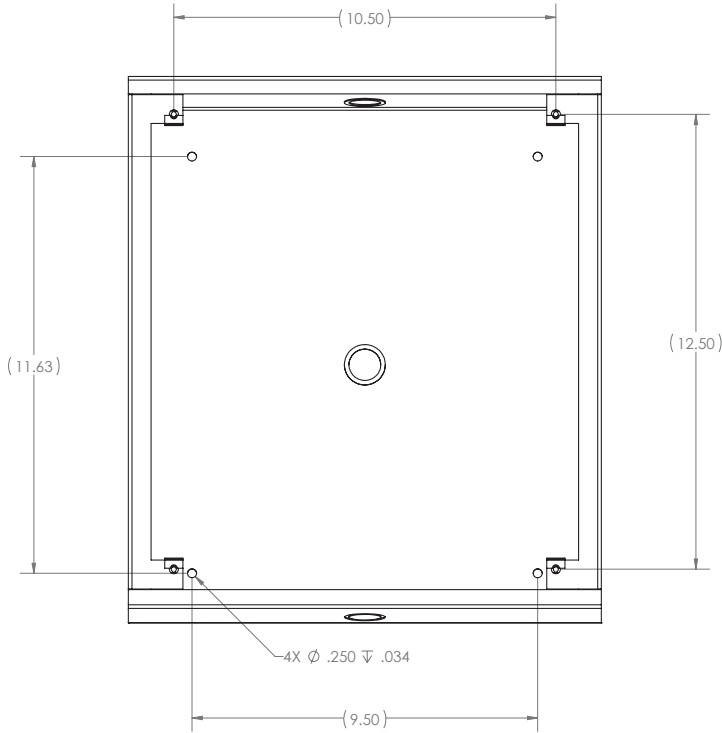
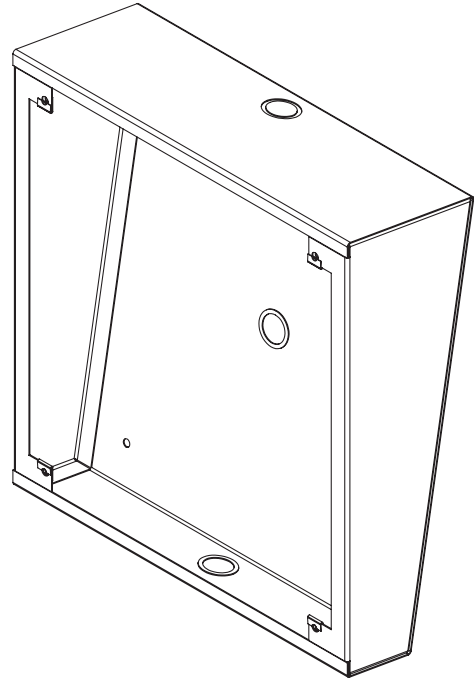
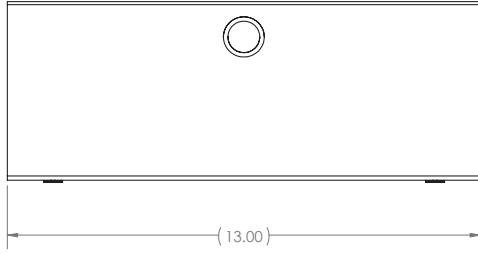

Accessories
IP-SEST-SD

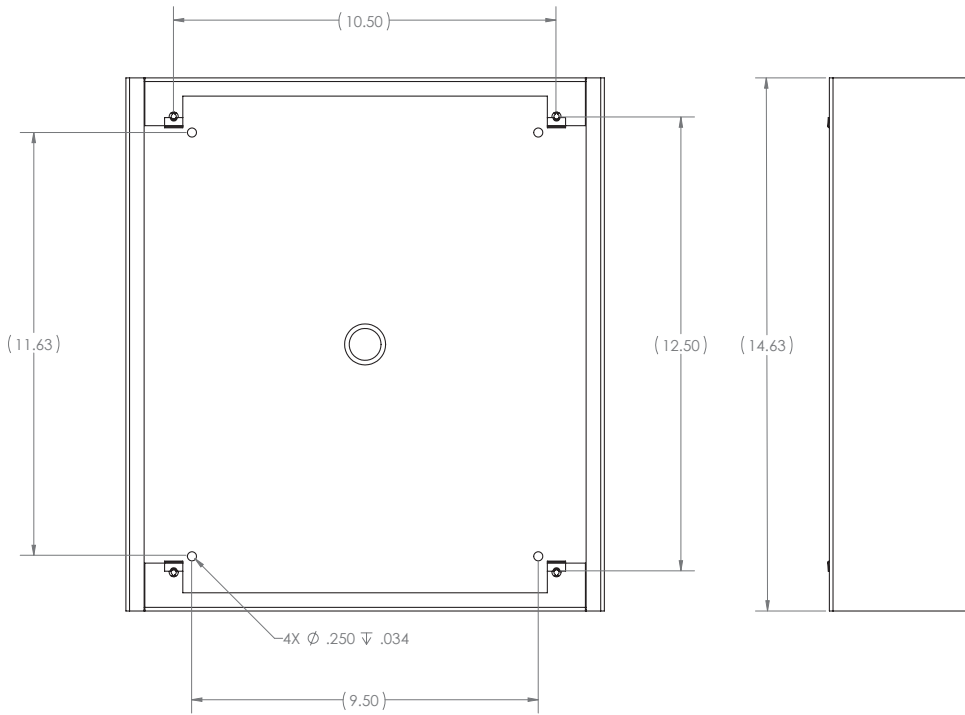
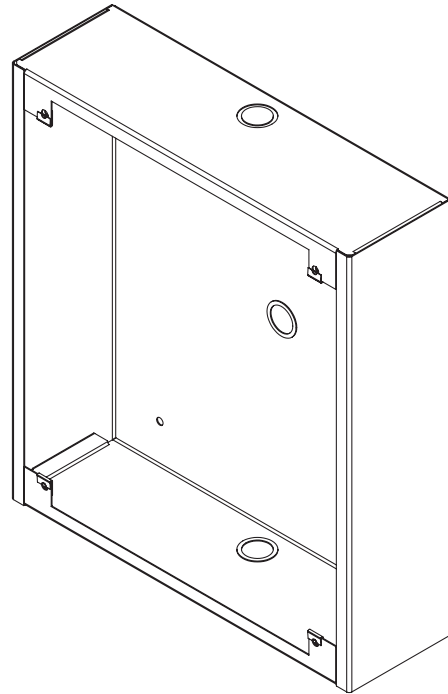
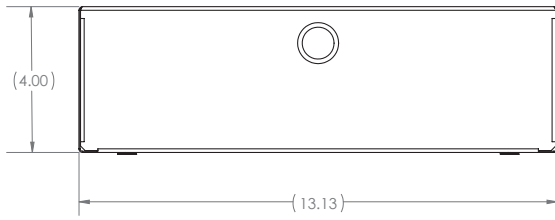

Accessories

IP-FEST-SD

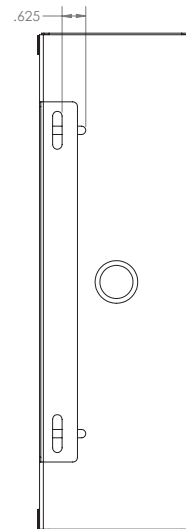
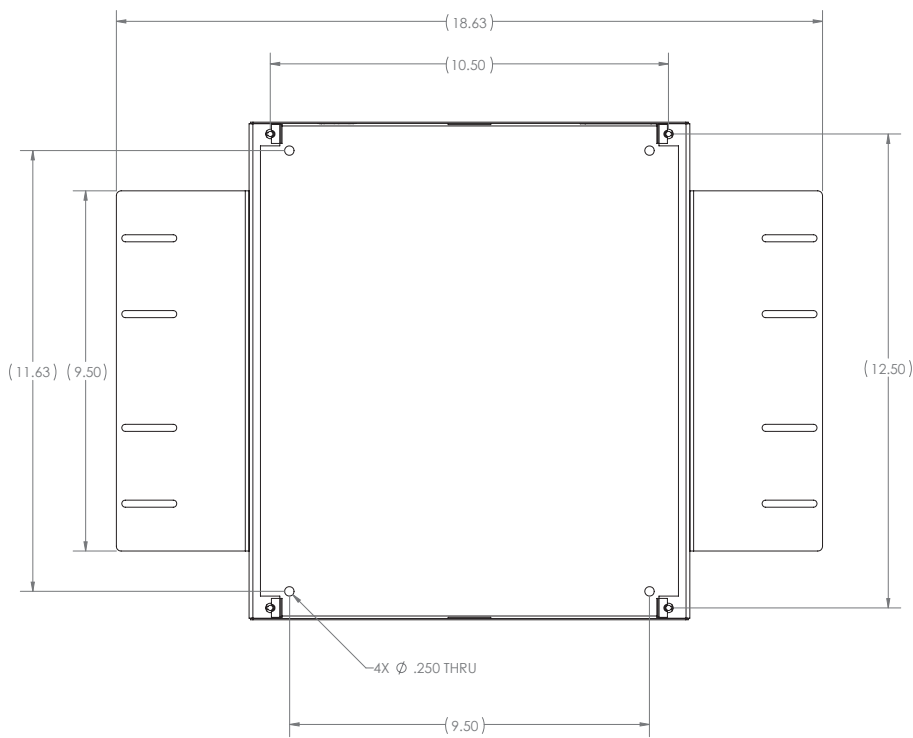
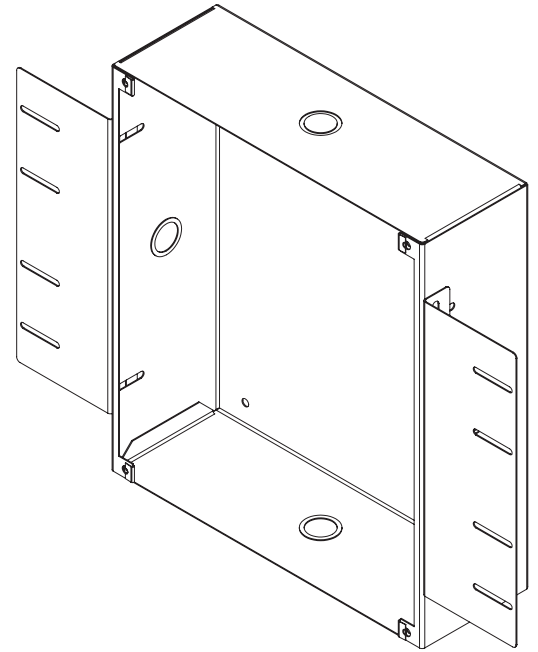
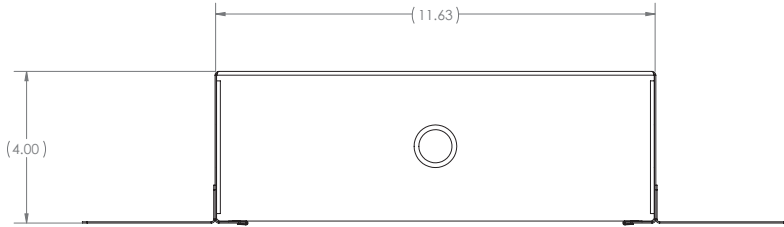

Architect and Engineer Specifications

The unit shall be AtlasIED model IP-SDMF. The PoE+ Indoor IP Endpoint Speaker System shall include factory assembled speaker, IP addressable PCB amplifier / control, plastic baffle, and integrated microphone.

The speaker shall be an 8" Coaxial driver with low-frequency reproducer cone shall be a full 8" (203mm) in diameter and the high frequency reproducer cone shall be 3" (76mm) in diameter. The woofer shall have a 10oz. (260g) ceramic magnet; the tweeter shall have a 2.35oz. (67g) ceramic magnet. The two reproducer sections shall be coupled through a built-in crossover network.

The crossover frequency shall be at 2800Hz. The speaker dispersion shall be 105° and frequency response range shall be 70Hz – 15.5kHz, (±5dB). Sensitivity shall be 98dB at 1 Watt / 1 meter. Voice coil impedance shall be 8 Ω. Low frequency voice coil diameter shall be 1" (25mm) and operate in a magnet field of at least 10,600 gauss. The maximum depth of the loudspeaker shall not exceed 2 7/8" (73mm).

The amplifier / control board shall receive announcements and messages using dynamically routed data on a standard Ethernet Network. It shall include a Single-Channel Class D Topology amplifier with Primary and Secondary Outputs capable of producing 25-watts RMS when using an IEEE 802.3at compatible PoE+ switch or 24VDC local power supply and 12-watts RMS when used with an IEEE 802.3af compliant PoE switch. Interconnect shall be via female RJ-45 connector mounted to the PCB.

The amplifier / control board shall include (2) logic inputs, (1) relay output, (1) Auxiliary Unbalanced line level audio input and (1) Unbalanced line level audio output. The Auxiliary Line Level input shall include an auto mute function that is activated when a broadcast is sensed from the control application.

The amplifier / control board shall include a Graphical User Interface (GUI) for SIP configuration. The SIP implementation shall support standards G.711, G.722 and RTP protocols. The Graphical User Interface (GUI) shall configure and manage logic inputs, relay outputs, and Auxiliary audio input.

The unit shall incorporate an integrated microphone to allow full duplex talkback communication functionality based upon chosen software platform.

The unit shall incorporate a High-Resolution Back-Lit color LCD display with viewable dimensions of 8.66" (221mm) wide x 2.23" (57mm) high. It shall receive visual notifications by AtlasIED's GCK, Syn-Apps' Revolution, Singlewire's InformaCast software platforms. It shall display time when in standby mode from AtlasIED's GCK, Syn-Apps' Revolution, Singlewire's InformaCast software platforms or by NTP. The display shall produce 1900 cd/m² lux brightness and display text and / or time.

The unit shall incorporate a LED flasher with viewable dimensions of 0.5" (13mm) height x 3.5" (89mm) wide. The LEDs shall be able to produce RGB color spectrum with brightness of 83-lux (Red), 545-lux (Green), 90-lux (Blue), 570-lux (White). It shall have the capability of multi-speed flash rate and will be software controllable.

All control functionality shall be determined via software. It shall be compatible with AtlasIED's GCK, Syn-Apps' Revolution, Singlewire's InformaCast software platforms and SIP standalone operation. The PoE+ Indoor IP Endpoint Speaker System overall dimensions shall be 14.38" (365mm) x 12.88" (327mm) x 3.42" (87mm). Finish shall be neutral white electrostatic powder coat micro perforated grille with plastic trim ring.

Optional enclosures shall include:

IP-SEA-SD	Surface mount angled enclosure for IP-SDMF neutral white finish
IP-SEST-SD	Surface mount straight enclosure for IP-SDMF neutral white finish
IP-FEST-SD	Flush mount straight enclosure for IP-SDMF reclaimed powder coat finish