

## PDA Range Selected Parts Listing

### PDA200E 200m<sup>2</sup> Induction Loop Amplifier & Kits

PDA200E	200m <sup>2</sup> wall-mounting induction loop amplifier
AKM1	PDA200E 200m <sup>2</sup> Meeting/seminar room loop kit c/w PDA200E amplifier, APM omni-directional mic plate/cable
AKL1	PDA200E 200m <sup>2</sup> Lecture room loop kit c/w PDA200E amplifier, AMT tie/desk mic, AML lectern mic, 2 x APJ plate/cable
AKT1	PDA200E 200m <sup>2</sup> TV / music lounge loop kit c/w PDA200E amplifier, AMH handheld mic, APS scart lead, APJ plate/cable, APL plate/cable
AKR1	PDA200E 200m <sup>2</sup> Waiting room loop kit c/w PDA200E amplifier, APL plate/cable
AKU1	PDA200E 200m <sup>2</sup> Retail unit loop kit c/w PDA200E amplifier, AML lectern mic, APJ plate/cable
AKW1	PDA200E 200m <sup>2</sup> Place of worship loop kit 1 c/w PDA200E amplifier, AML lectern mic, APJ plate/cable, APL plate/cable
AKW2/L	PDA200E 200m <sup>2</sup> Place of worship loop kit 2 (lavalier mic. version) c/w PDA200E amplifier, AMR/LA lavalier radio mic, APQM plate/cable, 2 x APXM plate/cable
AKW2/H	PDA200E 200m <sup>2</sup> Place of worship loop kit 2 (handheld mic. version) c/w PDA200E amplifier, AMR/HA handheld radio mic, APQM plate/cable, 2 x APXM plate/cable
AKH1/L	PDA200E 200m <sup>2</sup> Health and fitness club loop kit (lavalier mic. version) c/w PDA200E amplifier, AMR/LA lavalier radio mic, APQM plate/cable, APL plate/cable
AKH1/H	PDA200E 200m <sup>2</sup> Health and fitness club loop kit (handheld mic. version) c/w PDA200E amplifier, AMR/HA handheld radio mic, APQM plate/cable, APL plate/cable

### PDA Pro-Range Amplifiers and Mounting Kits

PDA200/2	200m <sup>2</sup> free-standing professional induction loop amplifier
PDA500/2	500m <sup>2</sup> free-standing professional induction loop amplifier
PDA1000/2	900m <sup>2</sup> free-standing professional induction loop amplifier
PDA/WM	Wall mounting kit for PDA200/2, 500/2 or 1000/2 amplifier
PDA/RM	19" Rack mounting kit for PDA200/2, 500/2 or 1000/2 amplifier

### Outreach Plates

APM	Omni-directional plated microphone, for wall/ceiling/desk mounting
APL	Dual phono line level outreach plate
APJ	3.5mm jack mic. level outreach plate
APQM	6.35mm (¼") jack mic. level outreach plate
APQL	6.35mm (¼") jack line level outreach plate
APXM	XLR 3 pin mic. level outreach plate
APXL	XLR 3 pin line level outreach plate
APXO	XLR 3 pin balanced line output outreach plate
API	AFILS active indicator light
BELDEN/10	10m Belden 8723 four core screened cable for use with outreach plates
BELDEN/25	25m Belden 8723 four core screened cable for use with outreach plates

### Induction Loop Testing Equipment

FPROK	Fosmeter Pro Induction Loop Test Kit (includes Fosmeter Pro loop tester, Audio signal generator & headphones.) Requires either AL3 lead for PDA102 / MLK1K / PDA200E or AL14 lead for Pro-Range amplifiers.
AL1	3.5mm jack to 3.5mm jack lead
AL2	3.5mm jack to double phono lead
AL3	3.5mm jack to bare ended lead
AL4	6.35mm (¼") jack to XLRM lead
AL12	3.5mm jack to 6.35mm (¼") jack socket adapter

### Induction Loop Ancillaries

APT	Loop connector plate (for the termination of induction loop cable)
LEST	100V line (i.e. PA system output) to 0db (775mV line level) convertor
APPS	Overspill reduction phase shifter
TEAR10	Pack of 10 self-adhesive 'induction loop in use' stickers

# PDA200E Induction Loop System Installation Guide

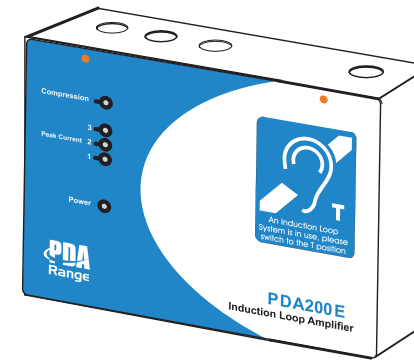

**PLEASE READ THESE INSTRUCTIONS CAREFULLY BEFORE INSTALLING AND / OR MAINTAINING THIS EQUIPMENT.**

## Key Features

The PDA200E is a cost-effective induction loop amplifier that is designed to drive a perimeter loop of up to 200 square metres. It provides the following key features:

- Fully compliant as a perimeter loop system as described in BS 7594, clause 10 A3 and BS EN 60118-4 when correctly installed
- Up to 200 square metres (metal free) coverage - ideal for most 'free space' applications
- Two balanced / unbalanced line level inputs
- One microphone input with phantom power for electret microphones (12 V)
- Full compatibility with the Outreach plate audio input extension system
- Metal compensation control to improve intelligibility in rooms with high metal content
- Fully automatic compressor-limiter which maintains the loop signal for improved intelligibility
- Each input has a separate internal tamper-resistant control that can be manually adjusted
- Compression, output (Peak Current 3, 2, 1) and power on (Power) front panel indicators
- Short circuit protection
- Internal temperature safety cut-out to stop over heating
- Wall-mounted metal enclosure for a permanent robust installation
- Complete with installation kit, instructions and 'loop fitted' sticker
- Contractor kits available - suitable for use in meeting rooms, TV lounges, places of worship, etc.



### Hint!

Additional information about loop design can be found in the PDA Guide to Audio-Frequency Induction Loop Systems (AFILS), Document Number DLM0503700.

## PDA200E Example Schematic

This schematic shows an example system which utilises a desk mounted microphone (AMT) directly wired into the PDA200E and two Outreach plate microphones (APM).

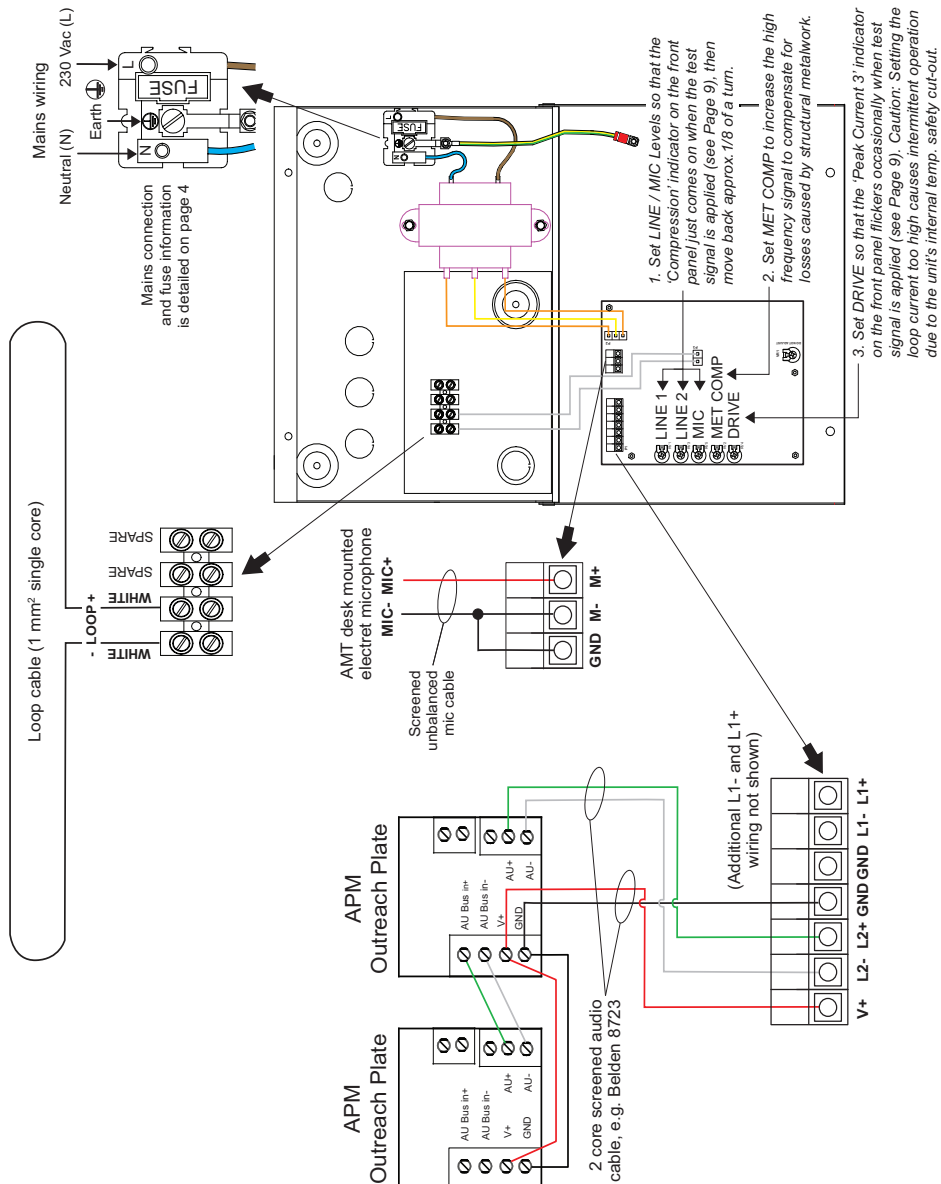

## Typical Outreach Plate Layout

Outreach plates can be daisy-chained to one balanced line level input, as shown below:

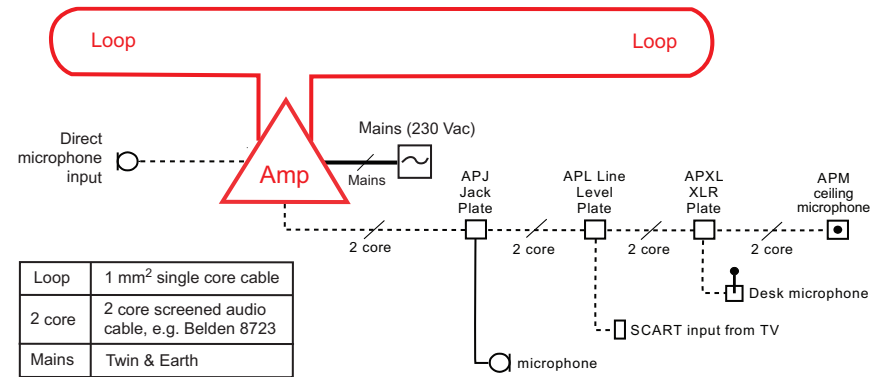

## PDA200E Technical Specification

<b>Power</b>	
Mains Voltage:	230 Vac, 50-60 Hz
Power Consumption:	< 80 VA
<b>Line Level Input (x2)</b>	
Impedance:	1k + or - input to ground
Sensitivity:	200 mV - 2.5 V RMS balanced or unbalanced
Input Voltage:	2.5 V max. or Outreach plates
<b>Performance</b>	
Bandwidth:	100 Hz - 5 kHz @ 0 dB
Distortion:	< 0.33% THD & @ 1 kHz 0 dB
<b>Microphone Input</b>	
Impedance:	1k + or - input to ground
Sensitivity:	1 - 8 mV balanced
Phantom Voltage:	12 Vdc
<b>Metal Compensation</b>	
Control:	3 dB / octave band (Boost)
<b>Output Drive Current</b>	
Maximum Peak:	> 6.2 A; continuous 4.2 A
<b>Loop Cable</b>	
Max. Area of Coverage:	200 m <sup>2</sup> (1 mm <sup>2</sup> cable) - metal free
Loop Impedance:	0.5 to 1 ohm @ 1 kHz. Will drive higher impedance loops with reduced area of coverage.
<b>Front Panel Indicators</b>	
Power:	Green LED
Compression:	Red LED
Peak Current (3, 2, 1):	(Red / Yellow / Green) Scale
<b>Physical</b>	
Weight:	2.9 kg
Dimensions (L x H x D):	273 mm x 200 mm x 77 mm
<b>Environmental</b>	
Ingress Protection:	IP20

## Outreach Plate Variants

The Outreach Plate audio input extension system comprises of wall, ceiling and desk mounted single gang plates designed to increase the audio input capability of an AFILS. They mix signals from various input sources into one balanced line level input which can be fed into the PDA200E's line input.

### Outreach Plate Input Variants

#### APM Omni-Directional Plated Microphone

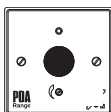

Self-contained omni-directional electret microphone complete with onboard mic. to line level converter. Typical coverage up to 25 m<sup>2</sup> (ambient) or 2.5 m<sup>2</sup> (direct speech) when located at ceiling height 2.5 to 3 m.

#### APXM XLR 3 Pin Microphone Plate

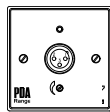

Accepts balanced or unbalanced microphones with standard 3 pin male XLR connectors. Includes on-board mic. to line level converter, high gain pre-amplifier and 12 V phantom power.

#### APL Dual Phono Line Level Plate

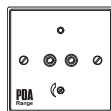

Accepts stereo phono line-level signals (typically from a stereo source, e.g. a TV, CD or DVD). Includes an on-board stereo line to mono converter. (An APS SCART to dual phono lead is also available.)

#### APXL XLR 3 Pin Line Level Plate

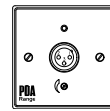

Accepts standard 3 pin male XLR feeds from audio equipment such as stage, or church mixing desks, etc.

#### APJ 3.5 mm Jack Microphone Plate



Accepts unbalanced electret microphones with 3.5 mm mono jack plugs. Includes an onboard microphone to line level converter, high gain pre-amplifier and 12 V phantom power.

#### APQM 6.35 mm (1/4") Jack Microphone Plate

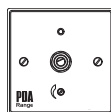

Accepts balanced or unbalanced electret microphones with 6.35 mm (1/4") jack plugs. Includes an on-board microphone to line level converter, high gain pre-amplifier and 12 V phantom power.

#### APQL 6.35 mm (1/4") Jack Line Level Plate

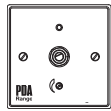

Accepts 6.35mm (1/4") jack feeds from audio equipment such as stage, or church mixing desks, etc.

### Outreach Plate Output Variants

#### APXO XLR 3 Pin Balanced Line Output Plate

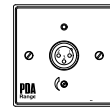

Provides an adjustable balanced line output (+12 dB max.) on a standard 3 pin male XLR connector. Typically used to connect an Outreach chain to third-party audio equipment such as conventional amplifiers.

#### API 'AFILS Active' Plate

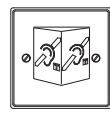

Includes two ultra-bright LEDs in a translucent diffuser overprinted with the AFILS 'ear' symbol. The LEDs illuminate when the Outreach network is powered to indicate that an AFILS system is installed.

### Microphones (available separately)

AMT - Tie Clip / Desk microphone	AMP - Phantom powered condenser microphone
AMH - Handheld microphone	AMR - Handheld or Lavalier radio microphone
AML - Lectern microphone	PRO45 - Hanging ambient microphone
AMD - Desktop microphone	G121 - Desk stand for AMH/AMP microphones



### Important Information

- This equipment is a piece of Class 1 equipment and **MUST BE EARTHED**.
- This installation guide **MUST NOT** be left accessible to the user.
- **ALWAYS** isolate the amplifier's Mains supply before making connections to its PCB.

#### Equipment guarantee

This equipment is not guaranteed unless the system is installed and commissioned in accordance with the relevant regional or national standards by an approved and competent person or organisation.

#### General precautions

DO NOT test wiring using an insulation tester (Megger) with any equipment connected as the 500 volt test voltage will destroy these devices totally and invalidate the warranty.

These instructions are general and cannot be considered to cover every aspect of a loop amplifier installation. E&OE. No responsibility can be accepted by the manufacturer or distributors of these units for any misinterpretation of this instruction, or for the compliance of the system as a whole. The manufacturer's policy is one of continuous improvement and we reserve the right to make changes to product specifications at our discretion and without prior notice.

## What is an audio-frequency induction loop system?



An audio-frequency induction loop system (AFILS) allows hearing impaired people, who are wearing a hearing aid fitted with a tele-coil, to hear more clearly. AFILS also minimise distracting and annoying background noise.

Most hearing aids have a 'T' or 'MT' switch which allows them to pick up the electromagnetic field generated by an induction loop system. The hearing aid converts this signal into a sound suited to its user's specific hearing requirements.

Any hearing impaired person positioned within or near the loop can hear the loop signal by switching their hearing aid to the correct position. This allows them to participate more effectively in general conversation, order goods or services, listen to public announcements, etc.

An induction loop system therefore comprises four main elements:

**The audio source** – typically a microphone, television / radio, or other line level audio source.

**The induction loop amplifier** – in this case the PDA200E.

**The loop** – typically a single turn of wire usually run around the perimeter of the room.

**The receiver(s)** – any hearing aid with a 'T' or 'MT' switch.

## PDA200E Kits

The PDA200E is supplied separately, or as part of a kit with Outreach plates which increase the number of audio inputs to the PDA200E. All kits (listed on page 12) include a PDA200E amplifier and 6 metres of Belden 8723 cable per Outreach plate. Contact your supplier for ordering kits.

## First Fix

Before any of the following is carried out ensure that the Mains supply is isolated.

### Equipment Location

All equipment must be sited indoors and **MUST NOT** be subjected to conditions likely to affect its performance, such as damp, salt air, water, extreme temperatures, physical abuse, etc. Wall mounted equipment should be sited at an easily accessible height.

### Remove knockouts

Decide how the wiring will be brought into the amplifier and remove the required knockouts for cable entry. A basic PDA200E system would require three knockouts; one each for Mains, loop cable and microphone / Outreach plates. If a knockout is removed fill the hole with a good quality cable gland. Unused knockouts must be securely blanked off.

### Observe proper segregation of wiring

Mains, loop and low power wiring must not come into contact, i.e. do not feed wiring through the same gland or allow wires of one type of connection to cross those of another.

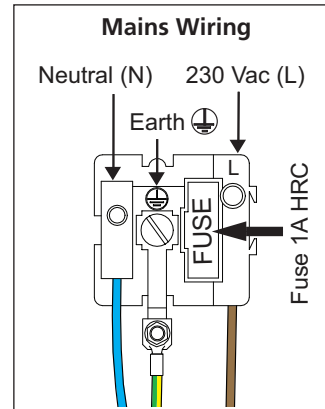
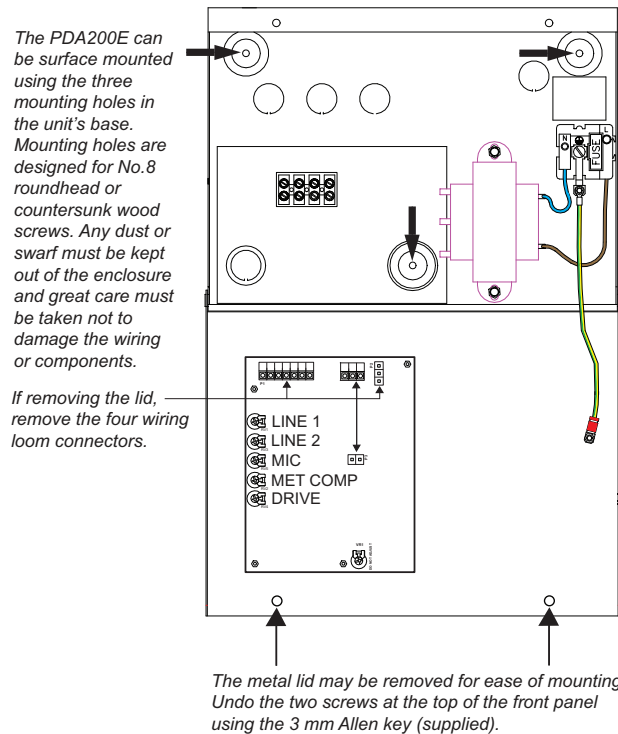

### Connect Mains to the PDA200E

The 230 Vac cable **MUST** enter the enclosure via one of the knock-outs at the top right hand corner of the enclosure.

This equipment requires fixed wiring, using three core cable (no less than 0.75 mm<sup>2</sup> and no more than 2.5 mm<sup>2</sup>) fed from a 3 amp fuse spur fitted with an isolating switch, located no more than 3 metres from the amplifier.

Terminate the Mains input lead using the fixed Mains connector on the base of the unit (shown above).

**This equipment is designed for permanent Mains connection and must not be connected using a plug and socket.**

## Second Fix

### Internal controls

Five internal pot controls (shown in diagram below) are located on the PDA200E's PCB, which is mounted internally on the unit's lid. The fully anti-clockwise position is the control's minimum setting (note that factory default setting is mid-position).

The **LINE 1** and **LINE 2** Level controls are used to set the signal levels of the line level inputs into the amplifier. Apply an audio source, such as a CD / test signal and adjust so that the 'Compression' red indicator (on the front panel) just comes on, then move back approximately 1/8 of a turn. If this indicator is either on constantly, or not on at all (with the signal present), then the amplifier may need further adjustment. If this level is set too high then the life span of the amplifier may be significantly shortened.

The **MIC** control is used to set the signal level of the microphone input. Adjust this control as per the LINE 1 and LINE 2 Level controls detailed above.

The **MET COMP** (metal compensation) control is used to compensate for the loss of high frequencies that occurs when significant amounts of metal are present. Turning the control clockwise boosts the range by +3 dB per octave.

The **DRIVE** control is used to increase / decrease the output current level supplied by the amplifier into the induction loop and should be set up after the 'Compression' has been set. Drive control should be set so that the 'Peak Current 3' red indicator (on the front panel) is either not on, or is just occasionally flashing. Adjusting this control to the point where this indicator is permanently lit may damage the amplifier.

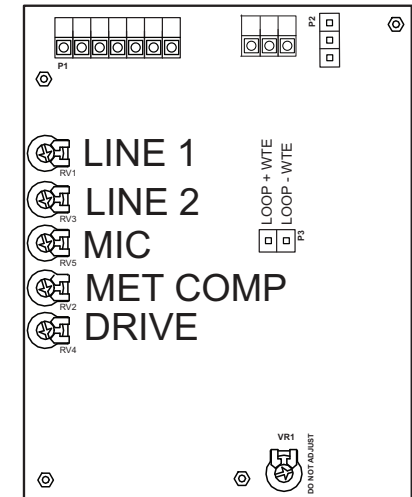

### Test the system

Apply an input test signal (microphone, line or Outreach) to the amplifier and check that the system works satisfactorily. Ideally, an induction loop listening device, or a national health hearing aid, should be used.

We recommend you check the loop system using an Induction Loop Test Kit (Part No. FPROK) which includes both a 400 mA/m Fosmeter Pro loop tester and an audio signal generator. This kit assists with the set up, testing and calibration of an AFILS for compliance with BS EN 60118-4.



### Hint!

Additional information about testing AFILS can be found in the Fosmeter Pro (FPRO) Instructions, Document Number DCM0004006.

## Overspill and more complex installations

The magnetic field is not confined to the area within the loop and the signal may be heard in adjacent areas such as a corridors and up to three times the width of the loop away. If this is a problem there are special designs of loop that can reduce the overspill field.

The AFILS British Standard (BS 7594) suggests several technically complex solutions that are reasonably effective but are not commonly employed due to high cost.

A low-cost but effective method to reduce overspill is to make a smaller loop, typically in the centre of a room. The smallest practicable loop for floor or ceiling mounting (up to 3 metres high) is 3 metres square. This will provide a reasonable field at head height above the loop and up to four metres away in all directions.

This loop may be installed above a suspended ceiling or in plastic conduit in the floor. Flat cable may be used under carpet.

In larger installations, and where overspill and/or an abundance of steel is present, a phase shifted loop array or 'super loop' may be required / specified. This is achieved by using an APPS phase shifter unit and laying two identical but offset loop patterns.

The APPS Overspill reduction phase shifter is part of the Outreach range of distributed mixer components. It is designed to take the signal from one or more Outreach plates and produce two signals that are 90° out of phase with each other. These signals are then fed into two (identical) induction loop amplifiers which are in turn connected to two loop patterns which are laid out in a special overlapping design. The resultant magnetic field is evenly spread within the loop but the strength falls off more quickly than outside a simple loop.

Please see diagram below (sizes shown are examples only as each system must be uniquely designed). Phase shifted loop designing is a free service available on request.

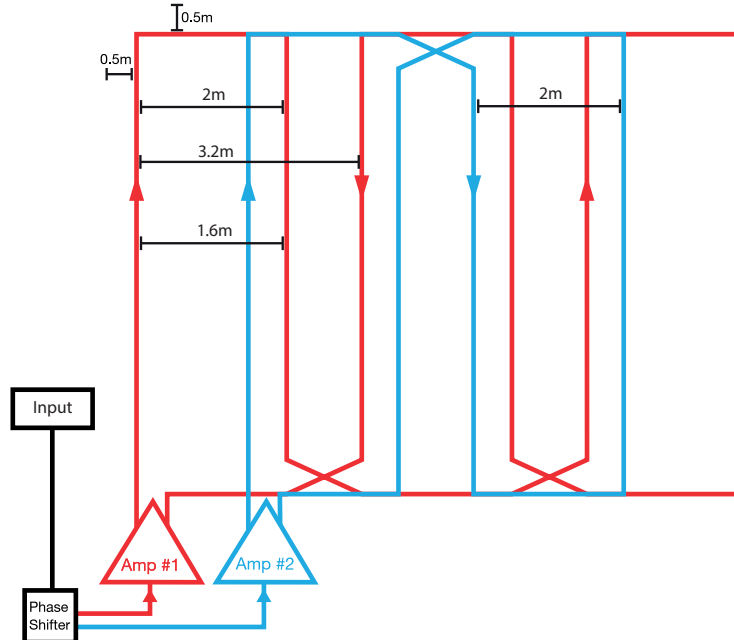

## Connecting Inputs

### Microphones (1 input available)

A Mic level input can be directly wired to the PDA200E Mic input as shown below.

Balanced microphones should be wired to GND, M- and M+ (M+ carries the 12 V phantom power). Unbalanced microphones (see Microphones, page 10), i.e. AMT (after removal of 3.5 mm jack plug), AML and AMD should be wired as signal+ to M+, Screen to GND and M- linked to GND.

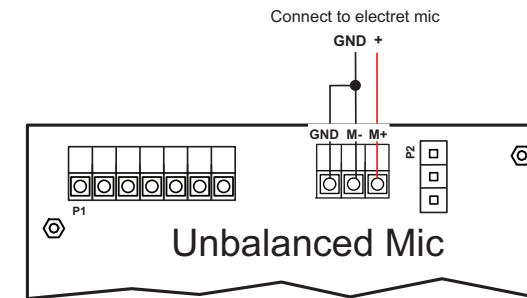
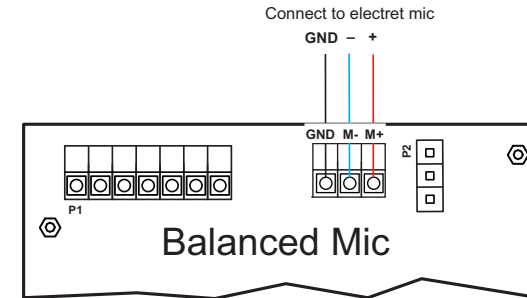

### Line Level (2 inputs available)

Unbalanced line level inputs should be wired as shown below with signal+ to L+, Screen to GND and L- linked to GND.

Balanced line level inputs should be wired using Outreach plates (detailed in next section).

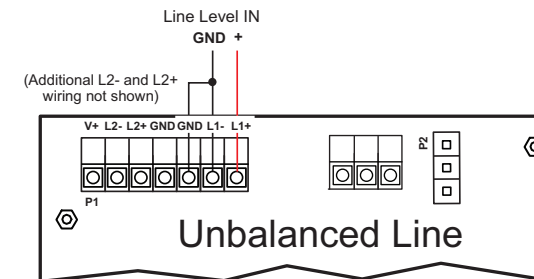



## Outreach Plate Wiring

Outreach plates increase the number of audio inputs to the PDA200E. They can be daisy-chained together and then connected as a single line level input as shown below.

1. Run the 2 core screened audio cable (supplied in kits) from the PDA200E to the first Outreach plate and secure with an appropriate gland.
2. Connect the PDA200E to the Outreach plates in accordance with:
  - V+ on PDA200E to V+ on Outreach plate
  - GND on PDA200E to GND on Outreach plate
  - L+ on PDA200E to AU+ on Outreach plate
  - L- on PDA200E to AU- on Outreach plate
3. Connect the 2nd Outreach plate (if required) to the 1st Outreach plate as shown below.
4. Fit the Outreach plate to the outlet box using the screws provided.

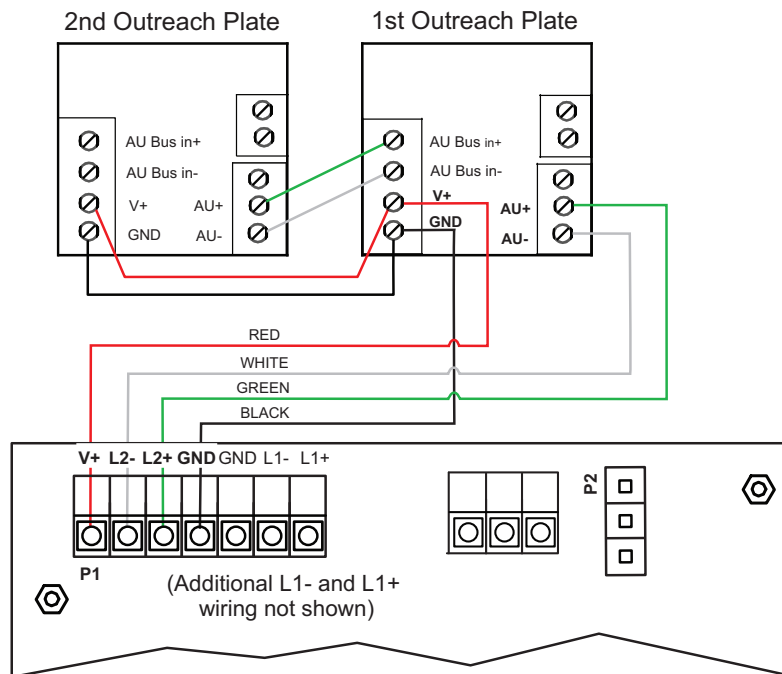

### Hint!

Additional information about Outreach plates can be found in the Outreach Plate Installation Guide, Document Number DCP0002212.

## Installing the Loop Cable

The loop cable should be laid in a single turn and wired into the PDA200E's termination block labelled LOOP- and LOOP+, as shown in the diagram on page 2 of this guide.

In the vast majority of cases loop cables are normally mounted horizontally around the perimeter of the room to be covered, either at ceiling or floor height. They may also be installed under carpet by using flat loop cable.

Do not install the loop cable closer than 1.2 metres to a hearing aid position.

The typical PDA200E installation (shown below) mounts the loop cable above the suspended ceiling and utilises two wall mounted microphones (APM).

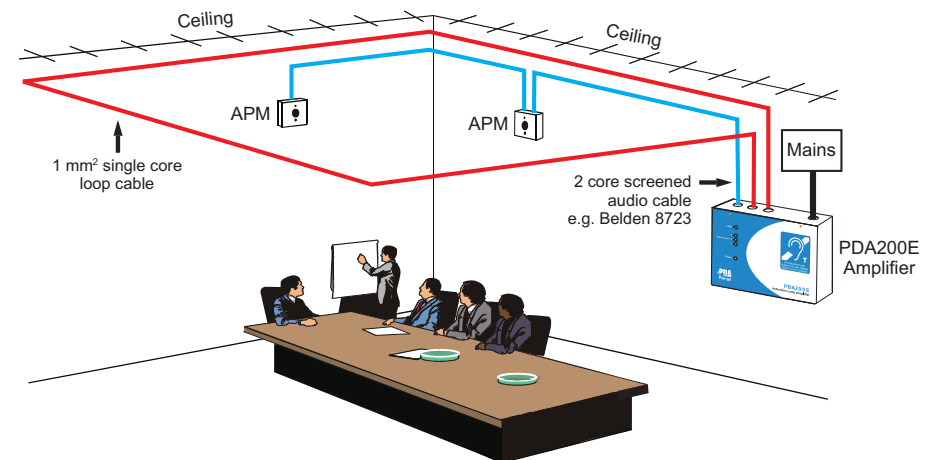

### Hint!

Additional information about loop design can be found in the PDA Guide to Audio-Frequency Induction Loop Systems (AFILS), Document Number DLM0503700 and also at [www.pdaloops.net](http://www.pdaloops.net).